

Water Specialist

1" Control Valve Series Model: WS1

1.25" Control Valve Series Model: WS1.25



Operation and Instruction Manual for OEM Only.

Please Note: This operation and instruction manual is for the training of the OEM and for the OEM to use to train their customers. This document is not to be used as the complete system manual.

Table of Contents

Introduction	4
General Warnings (Must appear in OEM's manual)	4
Specifications which must be included in OEM's Manual	5
Quick Reference Specifications	5
Control Valve Function and Cycles of Operation.....	6
Drive Assembly.....	10
Drive Cap Assembly, Main Piston and Regenerant Piston	10
Spacer Stack Assembly	10
Injector Cap, Screen, Injector Plug and Injector	11
Refill Flow Control Assembly or Refill Port Plug	11
Drain Line Flow Control and Fitting Assembly.....	12
Water Meter or Meter Plug.....	13
Mixing Valve.....	13
Installation Fitting Assemblies.....	13
Bypass Valve.....	14
OEM General Instructions.....	16
OEM Softener System Setup Quick Reference	17
OEM Filter System Setup Quick Reference	20
Installer Display Settings	22
User Display Settings.....	22
Diagnostics.....	24
Valve History.....	25
Installation	28
Drawings and Part Numbers.....	30
Front Cover and Drive Assembly.....	31
WS1 Drive Cap Assembly, Downflow Piston, Upflow Piston, Regenerant Piston and Spacer Stack Assembly	32
WS1.25 Drive Cap Assembly, Downflow Piston, Regenerant Piston and Spacer Stack Assembly	33
Injector Cap, Injector Screen, Injector, Plug and O-ring	34
Refill Flow Control Assembly and Refill Port Plug	35
Drain Line – 3/4"	36
Drain Line – 1".....	37
Water Meter, Meter Plug and Mixing Valve	38
Installation Fitting Assemblies.....	39
Bypass Valve.....	41
Flow Diagrams – Service and Backwash.....	42
Flow Diagrams – Downflow and Upflow	43
Flow Diagrams – Rinse and Fill.....	44
WS1 Wrench	45
Service Instructions	46
Troubleshooting.....	51
WS1 & WS1.25 Identification.....	53
Injector Graphs US Units: Injector Draw, Slow Rinse and Total Flow Rates.....	54
Injector Graphs Metric Units: Injector Draw, Slow Rinse and Total Flow Rates	56
Limited Warranty.....	60

Introduction

This manual is about a control valve to be used on water softeners or water filters. The manual is designed to aid water treatment equipment manufacturers in the selection of the various control valve options. Information in this manual is different than what is needed for installation and servicing of a particular water treatment system. This manual is not intended to be used as a manual for a complete water softener or filter. Certain parts of the manual will serve as aids to manufacturers in the writing and layout of the manuals for installers and service personnel.

General Warnings (*Must appear in OEM's manual*)

The following general warnings and the specifications in Table 1 must appear in the OEM's System Manual.

The control valve, fittings and/or bypass are designed to accommodate minor plumbing misalignments but are not designed to support the weight of a system or the plumbing.

Do not use Vaseline, oils, other hydrocarbon lubricants or spray silicone anywhere. A silicone lubricant may be used on black o-rings but is not necessary. **Avoid any type of lubricants, including silicone, on the clear lip seals.**

The nuts and caps are designed to be unscrewed or tightened by hand or with the special plastic wrench. If necessary a pliers can be used to unscrew the nut or cap. Do not use a pipe wrench to tighten or loosen nuts or caps. Do not place a screwdriver in the slots on caps and/or tap with a hammer.

Do not use pipe dope or other sealants on threads. Use teflon tape on threaded inlet, outlet and drain fittings. Teflon tape is not necessary on the nut connection or caps because of o-ring seals.

After completing any valve maintenance involving the drive assembly or the drive cap assembly and pistons, press and hold NEXT and REGEN buttons for 3 seconds or unplug power source jack from the printed circuit board (black wire) and plug back in. This resets the electronics and establishes the service piston position. The display should flash all wording, then flash the software version (e.g. 181) and then reset the valve to the service position.

All plumbing should be done in accordance with local plumbing codes. The pipe size for the drain line should be a minimum of ½". Backwash flow rates in excess of 7 gpm or length in excess of 20' require ¾" drain line.

Solder joints near the drain must be done prior to connecting the drain line flow control fitting. Leave at least 6" between the drain line control fitting and solder joints when soldering pipes that are connected on the drain line control fitting. Failure to do this could cause interior damage to the drain line flow control fitting.

When assembling the installation fitting package (inlet and outlet), connect the fitting to the plumbing system first and then attach the nut, split ring and o-ring. Heat from soldering or solvent cements may damage the nut, split ring or o-ring. Solder joints should be cool and solvent cements should be set before installing the nut, split ring and o-ring. Avoid getting primer and solvent cement on any part of the o-rings, split rings, bypass valve or control valve.

Plug into an electrical outlet. Note: All electrical connections must be connected according to local codes. (Be certain the outlet is uninterrupted.)

Install grounding strap on metal pipes.

Table 1
Specifications which must be included in OEM's Manual

Minimum/Maximum Operating Pressures	20 psi (138 kPa) -125 psi (862 kPa)	
Minimum/Maximum Operating Temperatures	40°F (4°C) - 110°F (43°C)	
AC Adapter:	<u>U.S.</u>	<u>International</u>
Supply Voltage	120 V AC	230V AC
Supply Frequency	60 Hz	50 Hz
Output Voltage	12 V AC	12 V AC
Output Current	500 mA	500 mA
No user serviceable parts are on the PC board, the motor, or the AC adapter. The means of disconnection from the main power supply is by unplugging the AC adapter from the wall.		

Table 2 contains a summary of specifications for the control valve and bypass valve.

Table 2
Quick Reference Specifications

Service flow rate 1" (includes bypass and meter)	27 gpm (102.2 lpm) @15 psig (103 kPa) drop	
Backwash flow rate 1" (includes bypass)	27 gpm (102.2 lpm) @25 psig (172 kPa) drop	
Service flow rate 1.25" (includes meter)	34 gpm (128.7 lpm) @15 psig (103 kPa) drop	
Service flow rate 1.25" (includes bypass and meter)	32 gpm (121.1 lpm) @15 psig (103 kPa) drop	
Backwash flow rate 1.25"	32 gpm (121.1 lpm) @25 psig (172 kPa) drop	
Backwash flow rate 1.25" (includes bypass)	30 gpm (113.5 lpm) @25 psig (172 kPa) drop	
Minimum/Maximum Operating Pressures	20 psi (138 kPa) -125 psi (862 kPa)	
Minimum/Maximum Operating Temperatures	40°F (4°C) - 110°F (43°C)	
AC Adapter:	<u>U.S.</u>	<u>International</u>
Supply Voltage	120 V AC	230V AC
Supply Frequency	60 Hz	50 Hz
Output Voltage	12 V AC	12 V AC
Output Current	500 mA	500 mA
Regenerant Refill Rate	0.5 gpm (1.9 lpm)	
Injectors	See Injector Graphs	
Drain Line Flow Controls	See Table 11	
Inlet / Outlet Fitting Options	<ul style="list-style-type: none"> - 1" NPT elbow which has a unique drill out feature to allow a 1/4" NPT connection to the inlet and/or outlet - 3/4" & 1" PVC solvent weld fitting - 3/4" or 1" straight brass sweat fittings - 1" or 1 1/4" plastic male NPT fittings - 1" or 1 1/4" plastic male BSPT fittings - 1 1/4" & 1 1/2" brass sweat fitting - 1 1/4" & 1 1/2" PVC solvent fitting - 3/4" or 1" PEX fittings 	
Distributor Tube Opening WS1 Valve	1.05" outside diameter (3/4" NPS)	
Distributor Tube Opening WS1.25 Valve	1.32" outside diameter (1" NPS)	
	32 mm outside diameter	
Tank Thread	2 1/2" - 8 NPSM	
Control Valve Weight	4.5 lbs.	2.0 kg
PC Board Memory	Nonvolatile EEPROM (electrically erasable programmable read only memory)	
Compatible with regenerants/chemicals	Sodium chloride, potassium chloride, potassium permanganate, sodium bisulfite, chlorine and chloramines	

Control Valve Function and Cycles of Operation

This glass filled Noryl¹ (or equivalent) fully automatic control valve is designed as the primary control center to direct and regulate all cycles of a water softener or filter. When the WS1 control valve is manufactured as a softener, the control valve can be ordered to perform downflow or upflow regeneration. The WS1.25 control valve is only available in downflow regeneration. When the WS1 or WS1.25 control valve is set up as a filter, the control valve can be set to perform downflow regeneration or simply backwash. The control valve can be set to regenerate on demand (consumption of a predetermined amount of water) and/or as a time clock (passage of a particular number of days). The control valve can be set so that a softener can meet the Water Quality Association (WQA) Standard S100 or NSF/ANSI Standard 44 efficiency rating.

It is not recommended to change control valves from downflow to upflow brining or vice versa in the field. The valve bodies for downflow and upflow are unique to the regeneration type and should not be interchanged. A mismatch of valve body and regeneration piston will result in hard water bypass during service.

The control valve is compatible with a variety of regenerants and resin cleaners. The control valve is capable of routing the flow of water in the necessary paths to regenerate or backwash water treatment systems. The injector regulates the flow of brine or other regenerants. The control valve regulates the flow rates for backwashing, rinsing, and the replenishing of treated water into a regenerant tank, when applicable.

The control valve uses no traditional fasteners (e.g. screws); instead clips, threaded caps and nuts and snap type latches are used. Caps and nuts only need to be firmly hand tightened because radial seals are used. Tools required to service the valve include one small blade screw driver, one large blade screw driver, pliers and a pair of hands. A plastic wrench is available which eliminates the need for screwdrivers and pliers. Disassembly for servicing takes much less time than comparable products currently on the market. Control valve installation is made easy because the distributor tube can be cut ½" above to ½" below the top of tank thread. The distributor tube is held in place by an o-ring seal and the control valve also has a bayonet lock feature for upper distributor baskets.

The AC adapter power pack comes with a 15 foot power cord and is designed for use with the control valve. The AC adapter power pack is for dry location use only. The control valve remembers all settings for up to 8 hours if the power goes out and the battery is not depleted. After 8 hours, the only item that needs to be reset is the time of day; other values are permanently stored in the nonvolatile memory. If a power loss lasts less than 8 hours and the time flashes on and off, the time of day should be reset and the non rechargeable battery should be replaced.

Table 3 shows the order of the cycles when the valve is set up as a softener. When the WS1 or WS1.25 control valve is used as a downflow softener, two backwashes always occur. The WS1.25 control valve may not be used as an upflow softener. When the WS1 control valve is used as an upflow softener (1" only), only one backwash occurs after brining. The OEM has the option of having the regenerant refill after the rinse cycle or have the regenerant prefill before regeneration. If the OEM chooses to have the regenerant prefill before regeneration, the prefill starts two hours before the regeneration time set. During the 2-hour period in which the brine is being made, treated (softened) water is still available. For example: regeneration time = 2:00 am, prefill option selected, downflow softener. Fill occurs at 12:00 a.m., start of backwash cycle occurs at 2:00 a.m.

When set up as a softener the backwash and rinse cycles automatically increase with increasing salt dosage. Backwashes can be set to be NORMAL or LONGER. The option selected will apply to all backwashes. Tables 4 and 5 show the length of the cycles when the valve is set up as a softener.

**Table 3
Regeneration Cycles Softening**

WS1 & WS1.25 Downflow Regenerant Refill After Rinse	WS1 & WS1.25 Downflow Regenerant Prefill	WS1 only Upflow Regenerant Refill After Rinse	WS1 only Upflow Regenerant Prefill
1 st Cycle: Backwash	1 st Cycle: Fill/Dissolve	1 st Cycle: Regenerate	1 st Cycle: Fill/Dissolve
2 nd Cycle: Regenerate	2 nd Cycle: Backwash	2 nd Cycle: Backwash	2 nd Cycle: Regenerate
3 rd Cycle: Backwash	3 rd Cycle: Regenerate	3 rd Cycle: Rinse	3 rd Cycle: Backwash
4 th Cycle: Rinse	4 th Cycle: Backwash	4 th Cycle: Fill/Dissolve	4 th Cycle: Rinse
5 th Cycle: Fill/Dissolve	5 th Cycle: Rinse	5 th Cycle: Service	5 th Cycle: Service
6 th Cycle: Service	6 th Cycle: Service		

¹ Noryl is a trademark of General Electric.

Table 4
Backwash Normal Length Softener
Cycle Times in Minutes

		WS1 & WS1.25 Downflow Softener			WS1 only Upflow Softener		
Grains Capacity/lb NaCl		6000 to 3501	3500 to 2501	2500 to 1700	6000 to 3501	3500 to 2501	2500 to 1700
lbs NaCl/cu ft resin ²		Less than 7.5	7.5 to 12	More than 12	Less than 7.5	7.5 to 12	More than 12
Cycle time in Minutes	Backwash Normal	6	8	8			
	Regenerate	45	60	75	45	60	75
	Backwash Normal	3	8	10	6	10	12
	Rinse	3	4	6	3	4	6
	Total ³	57	80	99	54	74	93

Table 5
Backwash Longer Length Softener
Cycle Times in Minutes

		WS1 & WS1.25 Downflow Softener			WS1 only Upflow Softener		
Grains Capacity/lb NaCl		6000 to 3501	3500 to 2501	2500 to 1700	6000 to 3501	3500 to 2501	2500 to 1700
lbs NaCl/cu ft resin ²		Less than 7.5	7.5 to 12	More than 12	Less than 7.5	7.5 to 12	More than 12
Cycle time in Minutes	Backwash Longer	8	10	12			
	Regenerate	45	60	75	45	60	75
	Backwash Longer	8	10	12	6	12	14
	Rinse	4	6	8	3	4	6
	Total ³	65	86	107	54	76	95

Table 6 shows the order of the cycles when the valve is set up as a filter. When the control valve is used as a downflow regenerating filter, the OEM has the option to specify one backwash or two backwashes. If the control valve is set to regenerate for a filter, the OEM has the option of having the regenerant refill after the rinse cycle or have the regenerant prefill before regeneration. If the OEM chooses to have the regenerant prefill before regeneration, the prefill starts two hours before the regeneration time set. During the 2-hour period in which the regenerant is being made, treated water is still available. For example: regeneration time = 2:00 am, prefill option selected, downflow filter. Fill occurs at 12:00 a.m., start of backwash cycle occurs at 2:00 a.m. There is only one rinse. Backwashes can be set to normal or longer. The option selected will apply to all backwashes. Tables 7 and 8 show the length of the cycles when the valve is set up as a filter.

When the control valve is used as a non-regenerating filter, the OEM has the option to specify one backwash or two backwashes. If two backwashes are specified, two rinses occur. Tables 7 and 8 show the length of the cycles when the valve is set up as a filter. When used as a non-regenerating filter, the downflow piston must be installed, the regenerant piston removed, injector plugs must be installed in both the DN and UP injector locations and the refill elbow must be replaced with a refill port plug.

² These are reference numbers that approximate the amount of salt needed. The actual capacity in grains per pound of salt is used in calculations.

³ Total time does not include fill time, which is dependent upon the amount of salt needed. When in the fill mode the system is providing treated water.

Table 6
Regeneration Cycles Filtering

WS1 & WS1.25 Downflow Regenerant Refill After Rinse	WS1 & WS1.25 Downflow Regenerant Prefill	WS1 & WS1.25 No Regeneration
1 st Cycle: Backwash 2 nd Cycle: Regenerate 3 rd Cycle: <i>Second Backwash*</i> 4 th Cycle: Rinse 5 th Cycle: Fill 6 th Cycle: Service	1 st Cycle: Fill 2 nd Cycle: Backwash 3 rd Cycle: Regenerate 4 th Cycle: <i>Second Backwash*</i> 5 th Cycle: Rinse 6 th Cycle: Service	1 st Cycle: Backwash 2 nd Cycle: Rinse 3 rd Cycle: <i>Second Backwash*</i> 4 th Cycle: <i>Second Rinse**</i> 5 th Cycle: Service

*Second backwash is optional

**Second rinse only occurs if Second Backwash option is selected.

Table 7
Regenerating Filter
Cycle Times in Minutes

	WS1 & WS1.25 Single Backwash		WS1 & WS1.25 Double Backwash	
	Normal	Longer	Normal	Longer
Backwash	14	16	8	12
Regenerate	60	60	60	60
2 nd Backwash			10	12
Rinse	8	10	8	10
Total ⁴	82	86	86	94

Table 8
Non-Regenerating Filter
Cycle Times in Minutes

	WS1 & WS1.25 Single Backwash		WS1 & WS1.25 Double Backwash	
	Normal	Longer	Normal	Longer
Backwash	14	16	8	12
Rinse	8	10	6	6
2 nd Backwash			10	12
2 nd Rinse			8	10
Total	22	26	32	40

The control valve with a water meter can be set for Demand Initiated Regeneration (DIR) only, Time Clock operation only or DIR and Time Clock which ever comes first, depending upon what settings are selected for Day Override and Gallon Capacity.⁵ See Table 9.

If a control valve does not contain a meter, the valve can only act as a time clock, and day override should be set to any number and gallon capacity should be set to off.

⁴ Total time does not include fill time, which is dependent upon the amount of fill needed. When in the fill mode the system is providing treated water.

⁵ See Installer Display Settings Step 3I, OEM Softener Setup Step 6S and OEM Filter Setup Step 5F for explanations of Day Override and Gallon Capacity.

Table 9
DIR/Time Clock Options

DIR	Time Clock	Reserve Capacity	Softener	Filter		Settings ⁶	
				Regenerant	Backwash Only	Day Override	Gallon Capacity
Yes		Automatically Calculated	Yes			Off	Auto
Yes		If desired enter a value less than estimated capacity	Yes	Yes	Yes	Off	Any Number
Yes	Yes	Automatically Calculated	Yes			Any Number	Auto
Yes	Yes	If desired enter a value less than estimated capacity	Yes	Yes	Yes	Any Number	Any Number
	Yes	None	Yes	Yes	Yes	Any Number	Off

For DIR Softeners, there are two options for setting the Gallons Capacity. The Gallons Capacity is automatically calculated if set to AUTO. Reserve Capacity is automatically estimated based on water usage if AUTO is used. The other option is to set the Gallons Capacity to a specific number. If a specific number is set, reserve capacity is zero, unless the value is manually set (i.e. the manufacturer intentionally sets the gallon capacity number below the calculated capacity of the system).

The WS1 & WS1.25 control valves can also be set to regenerate immediately or at the next regeneration time by changing the Regeneration Time Option. There are three choices for settings:

1. "NORMAL" means regeneration will occur at the preset regeneration time.
2. "on 0" means regeneration will occur when the gallons capacity reaches zero.
3. "NORMAL" and "on 0" means the regeneration will occur at the preset regeneration time unless the gallons capacity reaches zero. If the gallons capacity reaches zero the regeneration will begin 10 minutes after no water usage.

The user can initiate manual regeneration. The user has the option to request the manual regeneration at the delayed regeneration time or to have the regeneration occur immediately:

1. Pressing and releasing the REGEN button. "Regen Today" will flash on the display and the regeneration will occur at the delayed regeneration time. The user can cancel the request by pressing and releasing the REGEN button. This method of manually initiating regeneration is not allowed when the system is set to "on 0", i.e. to immediately regenerate when the gallon capacity reaches zero.
2. Pressing and holding the REGEN button for approximately 3 seconds will immediately start the regeneration. The user cannot cancel this request, except by resetting the control by pressing NEXT and REGEN buttons simultaneously for 3 seconds.

The WS1 & WS1.25 control valves consist of the following components:

1. Drive Assembly
2. Drive Cap Assembly, Main Piston and Regenerant Piston
3. Spacer Stack Assembly
4. Injector Cap, Screen, Injector Plug and Injector
5. Refill Flow Control Assembly or Refill Port Plug
6. Drain Line Flow Control and Fitting Assembly
7. Water Meter or Meter Plug
8. Mixing Valve (optional)
9. Installation Fitting Assemblies
10. Bypass Valve (optional)

Note: The WS1 & WS1.25 share many of the same components. Refer to Figure 6 for control valve identification.

⁶ Day Override and Gallon Capacity can not both be set to "oFF" at the same time.

Drive Assembly

The drive assembly consists of the following parts:

- Drive Bracket
- Printed Circuit (PC) Board
- Motor
- Drive Gears
- Drive Gear Cover

The drive bracket holds the PC board, the motor, the drive gears and the drive gear cover in place.

The PC board receives and retains information, displays the information, determines when to regenerate and initiates regeneration. The display shows different types of information in the initial system set up (for softeners or filters), installer display settings, diagnostics, valve history or user display settings. For a complete list of information see Table 14.

The PC board powers the motor. The PC board's two-prong jack connects wires to the direct current (DC) motor. The motor is held in place on the drive bracket by a spring-loaded clip and a small bulge in the plastic, which fits in one of the slots on the motor housing. The motor turns drive gears that drive the piston to cycle positions for backwashing, regeneration, rinsing, refill or service. The motor is fully reversible (turns both ways) and changes direction of rotation to change the direction of piston motion. The motor is easily replaced if necessary.

There are three drive gears held in place by the drive gear cover. All three drive gears are the same size. A reflective coating is applied to the gears. As the center drive gear turns a light shines on the coating and a light sensing diode determines if a light pulse was returned. The PC board counts the pulses and determines when to stop driving the motor.

Drive Cap Assembly, Main Piston and Regenerant Piston

The drive gears turn the main gear of the drive cap assembly, which moves the piston. The screw-driven, horizontally moving piston stops at specific positions to direct the flow of water to backwash, regenerate, rinse or refill. The PC board determines the position of the piston by counting pulses produced when the piston is moved. An optical sensor looking at one of the reduction drive gears generates these pulses. Each cycle position is defined by a number of pulses. The counter is zeroed each time the valve goes to the service position. The PC board finds the service position by noting the increase in current delivered to the motor when the mechanical stop at the service position is reached. This method of controlling piston position allows for greater flexibility and requires no switches or cams (U.S. Patent 6,444,127).

One of three main pistons is always used:

1. A 1.25" diameter downflow piston is used when the WS1 control valve is used as a downflow softener, regenerating filter or non-regenerating filter.
2. A 1.25" diameter upflow piston is used when the WS1 control valve is used as an upflow softener.
3. A 1.5" diameter downflow piston is used when the WS1.25 control valve is used as a downflow softener, regenerating filter or non-regenerating filter. An upflow piston is not available for the WS1.25 control valve.

If the control valve is used as a softener or a regenerating filter, a regenerant piston must be attached to the main piston. If the control valve is to be used on a system that does not require a regenerant to be added, the regenerant piston must be removed.

Spacer Stack Assembly

The spacer stack assembly provides the necessary flow passage for water during the different cycles. The all-plastic spacer stack assembly (U.S. Patent 6402944) is a one-piece design which allows the stack to be removed using your fingers.

The exterior of the stack is sealed against the body bore with self lubricating EPDM o-rings, while the interior surface is sealed against the piston using slippery self cleaning silicone lip seals. The lip seals are clear in color and have a special slippery coating so that the piston does not need to be lubricated.

Injector Cap, Screen, Injector Plug and Injector

The screen, injector and/or injector plug(s) are installed under the injector cap in an easy to access location on top of the valve. The injector cap contains four slots so no water accumulates in the cap. The injector cap is designed to be hand tightened.

Under the injector cap there is an easy to clean removable screen to prevent fouling of the injector. There are two holes under the injector cap labeled “DN” and “UP”. The holes will be filled with a plug or an injector.

The plug (Order # V3010-1Z) prevents water from traveling a certain pathway. The injector lets water pass through the pathway. The self-priming injector increases the velocity of the water, creating a zone of negative pressure that draws in the concentrated liquid regenerant, such as sodium chloride (brine), potassium permanganate, etc. The regenerant blends with the stream of water, which passes through the media to regenerate the bed.

The injector provides a consistent regenerant/water mixture ratio over the entire operating pressure range of the control valve. The injector provides good performance in a variety of applications, which may involve elevated drain lines and long regenerant draw lengths. Injectors are chosen by knowing the type, amount, and regenerant flow rate for a particular type of media. Guidelines can be found in the media manufacturer’s literature. The color coded injectors give different regenerant draw, slow rinse and total flow rates over the pressure range. See Table 10 for color codings, and injector graphs at the end of this manual for total, slow rinse and draw flow rates.

Table 10
Injector Order Information

Injector Order Number	Injector Color	Typical Tank Diameter ⁷	
		Down WS1 & WS1.25	Up WS1 Only
V3010-1A	Black	6"	8"
V3010-1B	Brown	7"	9"
V3010-1C	Violet	8"	10"
V3010-1D	Red	9"	12"
V3010-1E	White	10"	13"
V3010-1F	Blue	12"	14"
V3010-1G	Yellow	13"	16"
V3010-1H	Green	14"	18"
V3010-1I	Orange	16"	22"
V3010-1J	Light Blue	18"	
V3010-1K	Light Green	22"	

The control valve has been manufactured to be one of the following:

- regeneration downflow WS1 & WS1.25 (for softeners or regenerating filters install injector in DN location, plug in UP location)
- regeneration upflow WS1 only (upflow option is for softeners only, install injector in UP location, plug in other hole location)
- no regenerant WS1 & WS1.25 (both the DN and UP holes have injector plugs installed) and plug installed for the refill elbow

NOTE: It is not recommended to field convert valves from upflow to downflow and vice versa. Separate areas in the valve supply water to the injector for upflow and downflow valves.

Refill Flow Control Assembly or Refill Port Plug

The refill flow control assembly consists of a refill flow elbow, refill flow control retainer assembly, refill flow control, polytube insert and nut assembly. The refill flow control retainer fits in the refill elbow. The refill flow control retainer houses the refill flow control which controls the flow rate when the regenerant tank is being refilled. The refill flow control is a flexible washer-like part with a small orifice and a precision molded contour that delivers a steady 0.5 gpm regenerant tank refill rate at varying inlet pressures. Refill is accomplished with treated water.

⁷ Actual tank size used may vary depending on the design and application of the system. Tank diameter is an approximation for the following:

- A. downflow softener using standard mesh synthetic cation exchange media regenerating with sodium chloride.
- B. upflow softener using standard mesh synthetic cation exchange media regenerating with sodium chloride, an inlet water pressure of 30 to 50 psi and water temperature of 60°F water or warmer. Higher pressures or lower temperatures would need smaller injectors to avoid lifting the bed.

The refill flow control assembly is installed in an easy to access refill elbow located on top of the control valve. The refill flow control assembly is attached to the control valve with a locking clip. The locking clip allows the elbow to rotate 270 degrees so the outlet can be orientated towards the regenerant tank.

The control valve has a standard refill elbow to which a 3/8" flexible tube can be connected. An optional elbow can be ordered which accommodates a 1/2" flexible tube for a higher regenerant draw rate situation (G injectors and larger). Both elbows use the same refill flow control and retainer.

If the control valve is to be used as a non-regenerant filter control valve, the refill elbow is removed and replaced with a refill port plug P/N V3195-01.

Drain Line Flow Control and Fitting Assembly

The drain line flow control assembly includes a drain line flow control and a fitting. The drain line flow control allows proper media bed expansion by regulating the flow rate to the drain. The drain line flow control is a flexible washer-like part with an orifice and a precision molded contour. The flow rates are within $\pm 10\%$ over the pressure range of 20 psi to 125 psi. See Table 11 for flowrate information.

Table 11
Drain Line Flow Control and Fitting Assembly Information

Drain Line Fitting	Drain Line Flow Control Order No.	Number on Drain Line Flow Control	Backwash Flow Rate (gpm)	Backwash Flow Rate (lpm)
3/4"	V3162-007	007	0.7	2.6
3/4"	V3162-010	010	1.0	3.8
3/4"	V3162-013	013	1.3	4.9
3/4"	V3162-017	017	1.7	6.4
3/4"	V3162-022	022	2.2	8.3
3/4"	V3162-027	027	2.7	10.2
3/4"	V3162-032	032	3.2	12.1
3/4"	V3162-042	042	4.2	15.9
3/4"	V3162-053	053	5.3	20.1
3/4"	V3162-065	065	6.5	24.6
3/4"	V3162-075	075	7.5	28.4
3/4"	V3162-090	090	9.0	34.1
3/4"	V3162-100	100	10.0	37.9
1"	V3190-090	090	9.0	34.1
1"	V3190-100	100	10.0	37.9
1"	V3190-110	110	11	41.6
1"	V3190-130	130	13	49.2
1"	V3190-150	150	15	56.8
1"	V3190-170	170	17	64.3
1"	V3190-200	200	20	75.7
1"	V3190-250	250	25	94.6

The drain line flow control and fitting are located on top of the control valve and replaceable without the use of special tools.

The drain line flow control can be installed in the standard 3/4" drain line elbow, which accommodates 5/8" O.D. polytube or 3/4" NPT drain line connections. The optional nut and polytube insert for the 3/4" drain line elbow is designed for use with flexible polytube only. The 3/4" drain line elbow can be rotated 180 degrees so the outlet can be orientated to the nearest drain. The same retainer is used for all drain line flow controls for the 3/4" fitting. Drain line flow controls designed for the 3/4" fitting are available for flow rates ranging from 0.7 to 10 gpm.

An optional 1" straight drain line fitting is available to accommodate drain line flow rates ranging from 9 to 25 gpm. This fitting is straight but still connects to the control valve using the same locking clip. The drain line flow control is located between two fitted parts (i.e. the fitting acts as the retainer.) The nut is unscrewed to access the drain line flow control.

Water Meter or Meter Plug

The water meter is installed on the outlet side of the control valve. The water meter uses a turbine to measure gallons of treated water. The turbine rotates with the flow of water and reports its rate of rotation through Hall effect⁸ circuitry to the printed circuit (PC) board. This rotation permits the PC board to record the total volume of treated water and the flow rate. The small centrally located magnet is shielded from water, which substantially reduces iron-fouling problems with the turbine.

THIS WATER METER SHOULD NOT BE USED AS THE PRIMARY MONITORING DEVICE FOR CRITICAL HEALTH EFFECT APPLICATIONS.

The turbine is accurate to within $\pm 5\%$ over a wide operating flow rate range (0.25 gpm up to control valve maximums) and has a very low pressure drop. Water used for regeneration is not metered. If the control valve is set to refill the regenerant, water used between the refill cycle up to the start of the regeneration cycle is metered. If the control valve is in regeneration mode (e.g. a backwash cycle) and there is a water demand, that water usage is not metered.

When facing the front of the control valve, the water meter is positioned on the left-hand side of the control valve. Allow sufficient clearance to clean and repair the water meter without disconnecting the plumbing or disassembling any other parts of the control valve.

Control valves can be ordered with a meter plug (i.e. no electronics or turbine) rather than a water meter if desired. Control valves without meters should only be set up for time clock operation (i.e. no water meter, no demand-initiated regeneration). Control valves with water meters provide a wider variety of useful information (see OEM General Instructions for list of information).

A unique feature of this control valve is the ability to display actual water usage for the last 63 days. The values are initially stored as “----”. This means the value is unknown. As days pass values are stored as “0” for no flow or the actual number of gallons. The counting of the gallons starts at the regeneration time. If no regeneration time can be set (i.e. when the valve is set for immediate regeneration) the counting of gallons starts at 12 a.m. Day 1 is yesterday, day 2 the day before yesterday, etc. As new values are added the oldest history disappears.

Another unique feature is that the valve automatically calculates a reserve capacity when set up as a softener with “Gallons Capacity” set to “AUTO” and the “Regeneration Time Option” set to “Normal” or “Normal + on 0”. The actual reserve capacity is compared to the gallons capacity remaining immediately prior to the preset regeneration time. A regeneration will occur if the actual reserve capacity is less than the gallons capacity remaining. The actual reserve capacity is calculated by using the estimated reserve capacity and adjusting it up or down for actual usage.

The estimated reserve capacity for a given day of the week is the maximum value stored for the last three non-trivial water usages (i.e. more than 20 gallons/day) in seven day intervals.

Mixing Valve

The mixing valve is installed on the outlet side of the control valve. The mixing valve is used to blend raw water with treated water.

To adjust the blended water, close the mixing valve. Open a water faucet to the desired flow rate. Open the mixing valve until the desired hardness is reached. Close the faucet.

Installation Fitting Assemblies

The installation fittings are used to connect the optional bypass or the control valve to the plumbing system. These are the installation fitting assemblies available:

- 1” NPT PVC elbow fitting assembly
- 3/4” & 1” PVC solvent weld elbow fitting assembly
- 3/4” or 1” straight brass sweat fitting assemblies⁹
- 1” or 1 1/4” plastic male NPT fitting assemblies
- 1” or 1 1/4” plastic male BSPT fitting assemblies
- 1 1/4” & 1 1/2” brass sweat fitting assembly⁹
- 1 1/4” & 1 1/2” PVC solvent fitting assembly
- 3/4” or 1” PEX fitting assemblies⁹

The installation fitting assemblies are sold in pairs and consist of two fittings, two nuts, two split rings and two o-rings. The installation fitting assemblies and the bypass valve are sold separately from the control valve.

Both elbow fittings have a unique drill out feature to allow a 1/4” NPT connection to the inlet and/or outlet which can be used for a RO feed, test ports, pressure tap ports, etc.

⁸ Some semiconductor materials exhibit a phenomenon in the presence of a magnetic field that is adaptable to sensing devices. When a current is passed through one pair of wires attached to a semiconductor, another pair of wires properly attached and oriented with respect to the semiconductor will develop a voltage proportional to the magnetic field present and the current in the other pair of wires. Holding the exciting current constant and moving a permanent magnet near the semiconductor produces a voltage output proportional to the movement of the magnet. Hall effect devices provide a high speed response, excellent temperature stability, and no physical contact.

⁹ Has not been tested for compliance with California Proposition 65, so this fitting should not be installed in California.

Bypass Valve

The bypass valve is typically used to isolate the control valve from the plumbing system's water pressure in order to perform control valve repairs or maintenance. The WS1 bypass valve is particularly unique in the water treatment industry due to its versatility and state of the art design features. The full flow bypass valve incorporates four positions, including a diagnostic position that allows service personal to work on a pressurized system while still providing untreated bypass water to the facility or residence. Its completely non-metallic, all-plastic design allows for easy access and serviceability without the need for tools.

The bypass body and rotors are glass filled Noryl¹⁰ (or equivalent) and the nuts and caps are glass filled polypropylene. All seals are self-lubricating EPDM to help prevent valve seizing after long periods of non-use. Internal o-rings can easily be replaced if service is required.

The bypass consists of two interchangeable plug valves that are operated independently by red arrow-shaped handles. The handles identify the flow direction of the water. The plug valves enable the bypass valve to operate in four positions.

1. **Normal Operation Position:** The inlet and outlet handles point in the direction of flow indicated by the engraved arrows on the control valve. Water flows through the control valve during normal operation and this position also allows the control valve to isolate the media bed during the regeneration cycle. (See Figure 1)
2. **Bypass Position:** The inlet and outlet handles point to the center of the bypass, the control valve is isolated from the water pressure contained in the plumbing system. Untreated water is supplied to the plumbing system. (See Figure 2)
3. **Diagnostic Position:** The inlet handle points in the direction of flow and the outlet handle points to the center of bypass valve, system water pressure is allowed to the control valve and the plumbing system while not allowing water to exit from the control valve to the plumbing. (See Figure 3)
4. **Shut Off Position:** The inlet handle points to the center of the bypass valve and the outlet handle points in the direction of flow, the water is shut off to the plumbing system . If water is available on the outlet side of the softener it is an indication of water bypass around the system (i.e. a plumbing connection somewhere in the building bypasses the system). (See Figure 4)

¹⁰ Noryl is a trademark of General Electric.

BYPASS VALVE OPERATION

Figure 1

NORMAL OPERATION

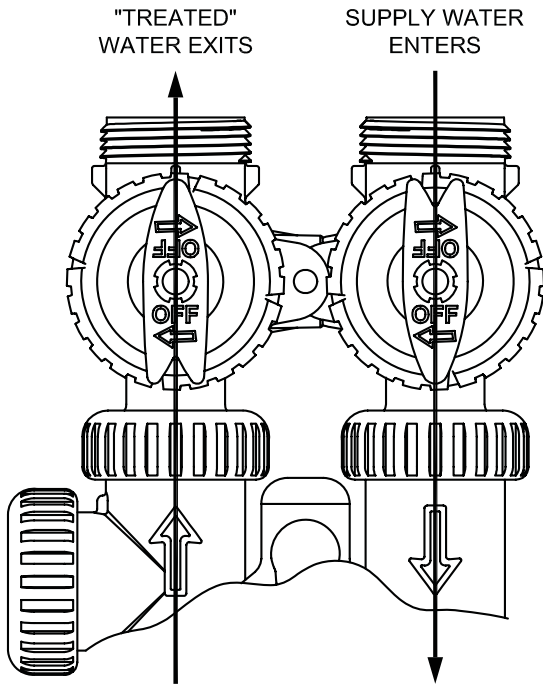

Figure 2

BYPASS OPERATION

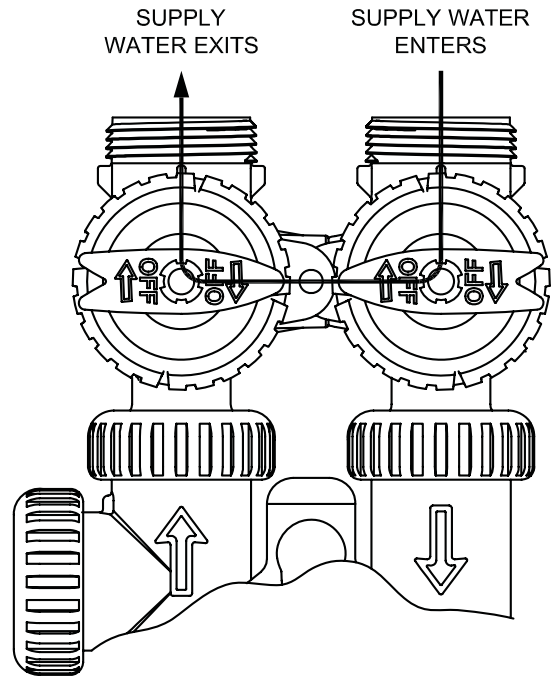

Figure 3

DIAGNOSTIC MODE

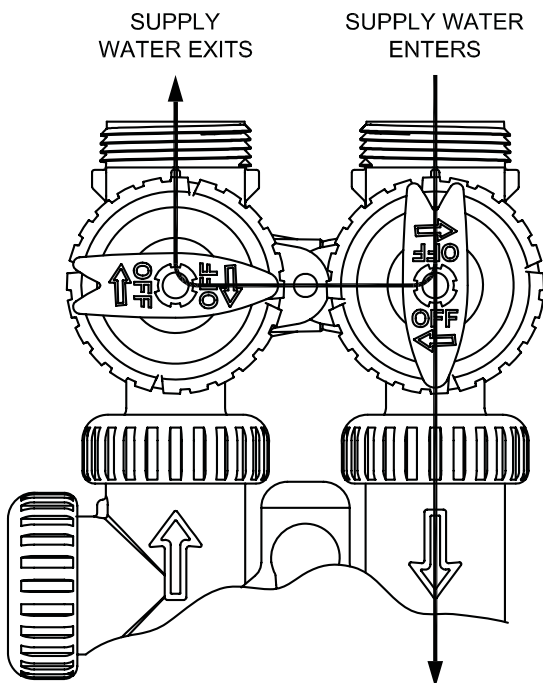
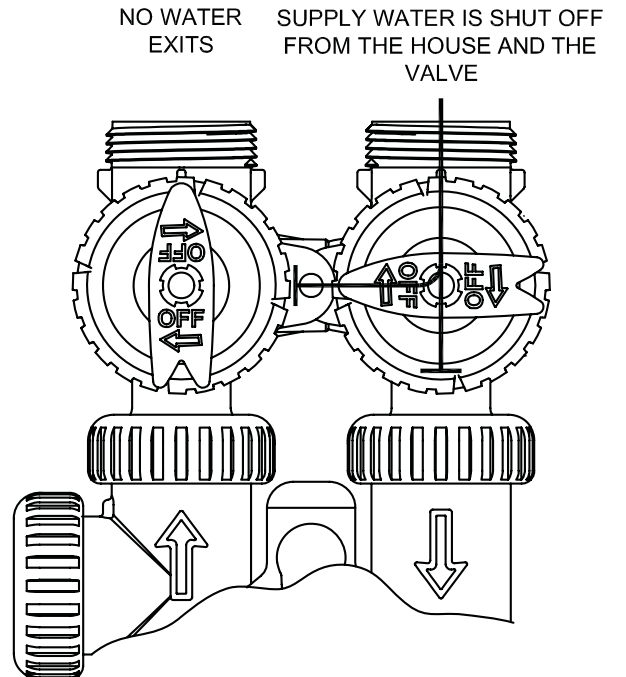

Figure 4

SHUT OFF MODE



OEM General Instructions

The control valve offers multiple procedures that allow the valve to be modified to suit the needs of the installation. These procedures are:

- OEM Softener Setup
- OEM Filter Setup
- Installer Displays & Settings
- User Displays & Settings
- Diagnostics
- Valve History

These procedures can be accessed in any order. Details on each of the procedures are provided on the following pages. Table 14 lists all information that may be displayed, where to find additional instructions about the information or instructions on how to access or change the information.

At the discretion of the manufacturer, the field technician can access all settings. To “lock out” access to diagnostic and valve history displays and modifications to settings except hardness, day override, time of regeneration and time of day by anyone but the manufacturer, press ▼, NEXT, ▲, and SET CLOCK in sequence after settings are made. To “unlock”, so other displays can be viewed and changes can be made, press ▼, NEXT, ▲, and SET CLOCK in sequence.

When in operation normal user displays such as time of day, gallons remaining or days remaining before regeneration are shown. When stepping through a procedure, if no buttons are pressed within five minutes the display returns to a normal user display. Any changes made prior to the five minute time out are incorporated. The one exception is current flow rate display under the diagnostic procedure. The current flow rate display has a 30 minute time out feature.

To quickly exit OEM Softener Setup, OEM Filter Setup, Installer Display Settings, Diagnostics or Valve History press SET CLOCK. Any changes made prior to the exit are incorporated.

When desired (e.g. when the valve is installed in a new location) certain information on the valve can be reset to zero. Table 14 identifies which information can be reset. To reset to zero, press NEXT and ▼ buttons simultaneously to go to the Service/OEM 1 screen, and release. Press ▲ and ▼ simultaneously to reset diagnostic values to zero. Screen will return to User Display.

Sometimes it is desirable to have the valve initiate and complete two regenerations within 24 hours and then return to the preset regeneration procedure. It is possible to do a double regeneration if the control valve is set to “NORMAL” or “NORMAL + on 0” in Step 9S or Step 7F. To do a double regeneration:

1. Press the “REGEN” button once. REGEN TODAY will flash on the display.
2. Press and hold the “REGEN” button for three seconds until the valve regeneration initiates.

Once the valve has completed the immediate regeneration, the valve will regenerate one more time at the preset regeneration time.

OEM Softener System Setup Quick Reference

This is a quick reference setup procedure. See OEM Softener System Setup Detail for more information on available settings.

STEP 1S – Press NEXT and ▼ buttons simultaneously for 3 seconds. If screen in step 2S does not appear in 5 seconds the lock on the valve is activated. To unlock press ▼, NEXT, ▲, and SET CLOCK in sequence, then press NEXT and ▼ simultaneously for 3 seconds.

STEP 2S – Choose Softening using ▼ or ▲ buttons. Press NEXT to go to Step 3S. Press REGEN to exit OEM Softener System Setup.

STEP 3S – Enter the ion exchange capacity in grains of hardness as calcium carbonate for the system based on test data using ▼ or ▲ buttons. Press NEXT to go to Step 4S. Press REGEN to return to previous step.

STEP 4S – Enter the pounds of salt per regeneration using ▼ or ▲ buttons. Press NEXT to go to Step 5S. Press REGEN to return to previous step.

STEP 5S – Backwash: Select “NORMAL” or “LONGER” using ▼ or ▲ buttons. See Tables 4 or 5 for backwash times. Press NEXT to go to Step 6S. Press REGEN to return to previous step.

STEP 6S – Set Gallons Capacity using ▼ or ▲ buttons:

- “AUTO” (reserve capacity automatically estimated and gallons capacity automatically calculated from grains capacity and water hardness);
- “oFF” (regeneration based on day override); or
- number of gallons (20 to 50,000).

See Table 12 for more detail. Press NEXT to go to Step 7S. Press REGEN to return to previous step.

STEP 7S – Set Refill option using ▼ or ▲ buttons:

- “PoST” to refill the brine tank after the final rinse; or
- “PrE” to refill the brine tank two hours before the regeneration time set.

Press NEXT to go to Step 8S. Press REGEN to return to previous step.

STEP 8S – Set regenerant downflow or upflow using ▼ or ▲ buttons:

- “dn” if the regenerant is to flow downward through the media; or
- “UP” if the regenerant is to flow upward through the media.

Prior to selecting a regenerant flow direction, verify the correct valve body, main piston, regenerant piston, and stack are being used, and that the injector or injector plug(s) are in the correct locations. See Compliance Table in Service Instructions under Injector Cap, Screen, Injector Plug and Injector section and Figure 6.

Press NEXT to go to Step 9S. Press REGEN to return to previous step.

STEP 9S – Set Regeneration Time Option using ▼ or ▲ buttons:

- “NORMAL” means regeneration will occur at the preset time;
- “on 0” means regeneration will occur immediately when the gallons capacity reaches 0 (zero); or
- “NORMAL + on 0” means regeneration will occur at one of the following:
 - the preset time when the gallons capacity falls below the reserve or the specified number of days between regenerations is reached whichever comes first; or
 - after 10 minutes of no water usage when the gallon capacity reaches 0 (zero).

See Table 12 for more detail. Press NEXT to exit OEM Softener System Setup. Press REGEN to return to previous step.

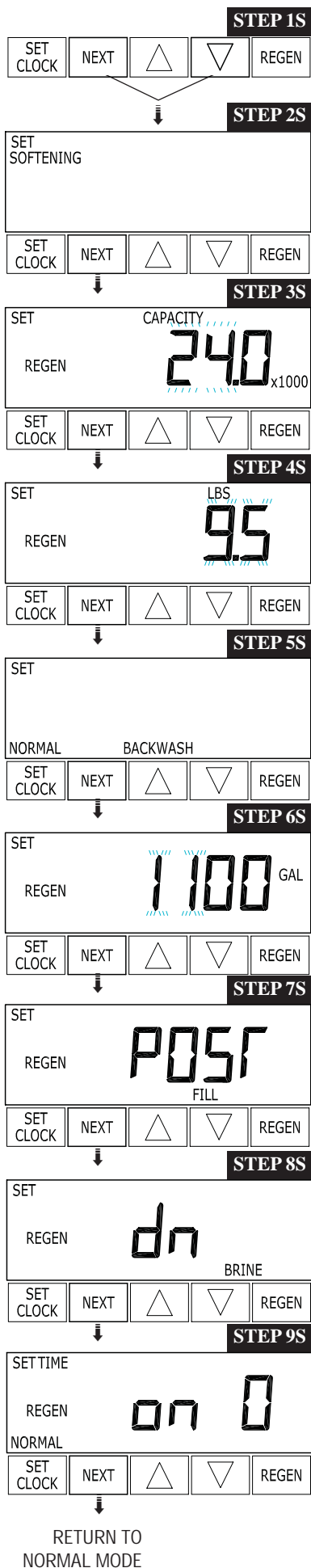

RETURN TO
NORMAL MODE

Table 12
Softener Setting Options

Gallons Capacity	Regeneration Time Option	Day Override	Result ¹¹
AUTO	NORMAL	oFF	Reserve capacity automatically estimated. Regeneration occurs when gallons capacity falls below the reserve capacity at the next Regen Set Time.
AUTO	NORMAL	Any number	Reserve capacity automatically estimated. Regeneration occurs at the next Regen Set Time when gallons capacity falls below the reserve capacity or the specified number of days between regenerations is reached.
Any number	NORMAL	oFF	Reserve capacity <u>not</u> automatically estimated. Regeneration occurs at the next Regen Set Time when gallons capacity reaches 0.
oFF	NORMAL	Any number	Reserve capacity <u>not</u> automatically estimated. Regeneration occurs at the next Regen Set Time when the specified number of days between regenerations is reached.
Any number	NORMAL	Any number	Reserve capacity <u>not</u> automatically estimated. Regeneration occurs at the next Regen Set Time when gallons capacity reaches 0 or the specified number of days between regenerations is reached.
AUTO	On O	oFF	Reserve capacity <u>not</u> automatically estimated. Regeneration occurs immediately when gallons capacity reaches 0. Time of regeneration will not be allowed to be set because regeneration will always occur when gallons capacity reaches 0.
Any number	On O	oFF	Reserve capacity <u>not</u> automatically estimated. Regeneration occurs immediately when gallons capacity reaches 0. Time of regeneration will not be allowed to be set because regeneration will always occur on 0.
AUTO	NORMAL on 0	oFF	Reserve capacity automatically estimated. Regeneration occurs when gallons capacity falls below the reserve capacity at the next Regen Set Time or regeneration occurs after 10 minutes of no water usage when gallon capacity reaches 0.
AUTO	NORMAL on 0	Any number	Reserve capacity automatically estimated. Regeneration occurs at the next Regen Set Time when gallons capacity falls below the reserve capacity or the specified number of days between regenerations is reached or regeneration occurs after 10 minutes of no water usage when gallon capacity reaches 0.
Any number	NORMAL on 0	Any number	Reserve capacity <u>not</u> automatically estimated. Regeneration occurs at the next Regen Set Time when the specified number of days between regenerations is reached or regeneration occurs after 10 minutes of no water usage when gallon capacity reaches 0.

¹¹Reserve capacity estimate is based on history of water usage.

OEM Softener System Setup Detail

STEP 1S – Press NEXT and ▼ simultaneously for 3 seconds. If screen in step 2S does not appear in 5 seconds the lock on the valve is activated. To unlock press ▼, NEXT, ▲, and SET CLOCK in sequence, then press NEXT and ▼ simultaneously for 3 seconds.

STEP 2S - Softening or Filtering: First the OEM must set the valve for use as a softener. Press ▼ or ▲ to choose softening. Press NEXT to go to Step 3S. Press REGEN to exit OEM Softener System Setup.

STEP 3S – Grains Capacity: Enter the ion exchange capacity in grains of hardness as calcium carbonate for the system based on the pounds of salt that will be set in the next step. The allowable range varies from 5,000 to 200,000 grains.¹² The increment increase is 500 for the range from 5000 to 30,000; 1000 for the range of 30,000 to 100,000; and 2000 for the range of 100,000 to 200,000. Press NEXT to go to Step 4S. Press REGEN to return to previous step.

STEP 4S – Pounds Salt: Enter the pounds of salt per regeneration. The range varies from a low of 0.8 to a high of 117. Press NEXT to go to Step 5S. Press REGEN to return to previous step.

STEP 5S – Backwash: Select “NORMAL” or “LONGER”. Selection effects the length of all backwashes. The actual duration of backwash automatically increases with higher salt dosages (see Tables 4 and 5 for additional details). Press NEXT to go to Step 6S. Press REGEN to return to previous step.

STEP 6S – Gallons Capacity: If value is set to:

- “AUTO” gallon capacity will be automatically calculated and reserve capacity will be automatically estimated;
- “oFF” regeneration will be based solely on the day override set (see Installer Display Settings step 3I); or
- as a number (allowable range 20 to 50,000) regeneration initiation will be based off the value specified.

Increment increase is 20 for the range of 20 to 1000; 50 for the range of 1000 to 10,000 and 100 for the range of 10,000 to 50,000. If “oFF” or a number is used, hardness display will not be allowed to be set in Installer Display Settings.¹³ See Table 12 for more detail. Press NEXT to go to Step 7S. Press REGEN to return to previous step.

STEP 7S – Refill: Select “PoST” to refill the brine tank after the final rinse or select “PrE” to refill the brine tank two hours before the regeneration time set. Press NEXT to go to Step 8S. Press REGEN to return to previous step.

STEP 8S – Downflow or upflow: Select “dn” if the regenerant is to flow downward through the media. Select “UP” if the regenerant is to flow upward through the media.¹⁴ Prior to selecting a regenerant flow direction, verify the correct valve body, main piston, regenerant piston, and stack are being used, and that the injector or injector plug(s) are in the correct locations. See Compliance Table in Service Instructions under Injector Cap, Screen, Injector Plug and Injector section and Figure 6. Press NEXT to go to Step 9S. Press REGEN to return to previous step.

STEP 9S – Regeneration Time Option: Three choices for settings are available “NORMAL”, “on 0” and “NORMAL + on 0”. See Table 12 for more detail. Press NEXT to exit OEM Softener System Setup. Press REGEN to return to previous step.

¹² Grains of capacity is affected by the salt dose setting. The capacity for that salt dosage should be confirmed by OEM testing. The capacity and hardness levels entered are used to automatically calculate reserve capacity when gallon capacity is set to AUTO.

¹³ It is suggested the “AUTO” setting be used in order to insure a proper reserve capacity.

¹⁴ Check to insure the main piston and injector location correspond to the downflow or upflow selection. For “dn” the main piston is entirely amber and the injector is in the hole labeled “dn”. For “UP” the main piston is amber and black and the injector is in the hole labeled “UP” and the letters DN are removed from the valve body. The color of the piston can be viewed by shining a flashlight through the drain port.

OEM Filter System Setup Quick Reference

This is a quick reference setup procedure. See OEM Filter System Setup Detail for more information on available settings.

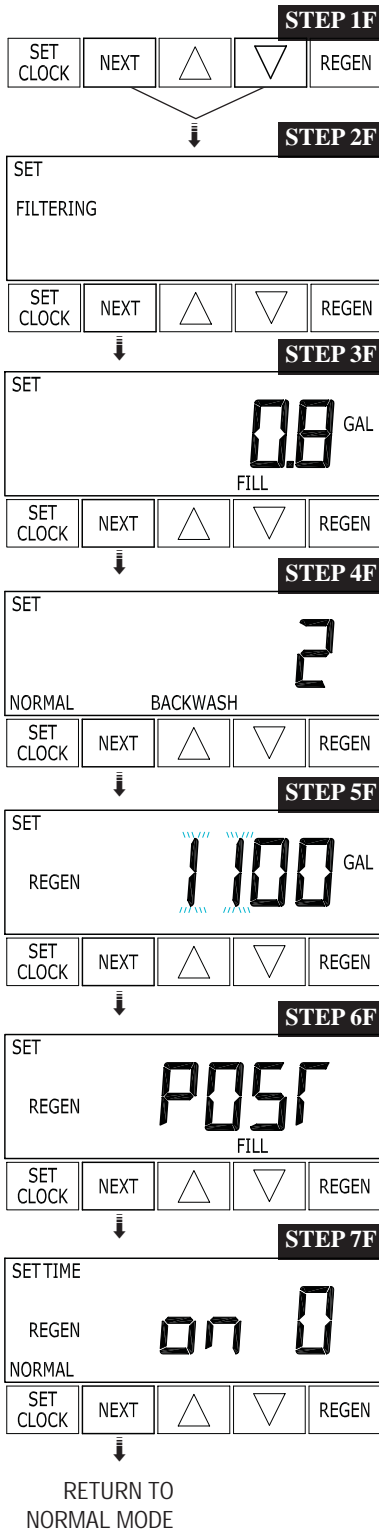

STEP 1F – Press NEXT and simultaneously for 3 seconds. If screen in step 2F does not appear in 5 seconds the lock on the valve is activated. To unlock press , NEXT, , and SET CLOCK in sequence, then press NEXT and simultaneously for 3 seconds.

STEP 2F – Choose Filtering using or buttons. Press NEXT to go to step 3F. Press REGEN to exit OEM Filter System Setup.

STEP 3F – Enter “oFF” if regenerant is not used (i.e. backwash only) or enter the refill volume (in gallons) using or buttons. Prior to selecting oFF or regenerant volume, verify the correct valve body, main piston, regenerant piston, and stack are being used, and that the injector or injector plug(s) are in the correct locations. See Compliance Table in Service Instructions under Injector Cap, Screen, Injector Plug and Injector section and Figure 6. Press NEXT to go to step 4F. Press REGEN to return to previous step.

STEP 4F – Backwash: Select using or buttons:

- “NORMAL” for one “NORMAL” backwash (14 minutes);
- “NORMAL 2” for two “NORMAL” backwashes (8 minutes each);
- “LONGER” for one “LONGER” backwash (16 minutes); or
- “LONGER 2” for two “LONGER” backwashes (12 minutes each).

See Tables 7 and 8 for additional details. Press NEXT to go to step 5F. Press REGEN to return to previous step.

STEP 5F – Set Gallons Capacity using or buttons:

- “oFF” (regeneration based on day override); or
- number of gallons (20 to 50,100).

See Table 13 for more detail. Press NEXT to go to step 6F. Press REGEN to return to previous step.

STEP 6F – Set Refill option using or buttons:

- “PoST” to refill the brine tank after the final rinse; or
- “PrE” to refill the brine tank two hours before the regeneration time set.

Press NEXT to go to step 7F. Press REGEN to return to previous step.

STEP 7F – Set Regeneration Time Option using or buttons:

- “NORMAL” means regeneration will occur at the preset time;
- “on 0” means regeneration will occur immediately when the gallons capacity reaches 0 (zero); or
- “NORMAL + on 0” means regeneration will occur at one of the following:
 - the preset time when the specified number of days between regenerations is reached; or
 - after 10 minutes of no water usage when the gallon capacity reaches 0 (zero).

See Table 13 for more detail. Press NEXT to exit OEM Filter System Setup. Press REGEN to return to previous step.

**Table 13
Filter Setting Options**

Gallons Capacity	Regeneration Time Option	Day Override	Result
oFF	NORMAL	Any number	Reserve capacity <u>not</u> automatically estimated. Regeneration occurs at the next Regen Set Time when the specified number of days between regenerations is reached.
Any number	NORMAL	oFF	Reserve capacity <u>not</u> automatically estimated. Regeneration occurs at the next Regen Set Time when gallons capacity reaches 0.
Any number	NORMAL	Any number	Reserve capacity <u>not</u> automatically estimated. Regeneration occurs at the next Regen Set Time when gallons capacity reaches 0 or the specified number of days between regenerations is reached.
Any number	On 0	oFF	Reserve capacity <u>not</u> automatically estimated. Regeneration occurs immediately when gallons capacity reaches 0. Time of regeneration will not be allowed to be set because regeneration will always occur on 0.
Any number	NORMAL on 0	Any number	Reserve capacity <u>not</u> automatically estimated. Regeneration occurs at the next Regen Set Time when the specified number of days between regenerations is reached or regeneration occurs after 10 minutes of no water usage when gallon capacity reaches 0.

OEM Filter System Setup Detail

STEP 1F – Press NEXT and ▼ simultaneously for 3 seconds. If screen in step 2F does not appear in 5 seconds the lock on the valve is activated. To unlock press ▼, NEXT, ▲, and SET CLOCK in sequence, then press NEXT and ▼ simultaneously for 3 seconds.

STEP 2F - Softening or Filtering: First the OEM must set the valve for use as a filter. Press ▼ or ▲ to choose filtering. Press NEXT to go to step 3F. Press REGEN to exit OEM Filter System Setup.

STEP 3F – Fill Volume: If the filter design does not require a regenerant the value is set to “oFF”. If a regenerant is required, the volume of refill (in gallons) can be set to the desired value. The default value is 0.8 and the value ranges from 0.1 to 100.0. The increment increase is 0.1 for the range of 0.1 to 10.0; 0.5 for the range of 10.0 to 50.0 and 1.0 for the range of 50.0 to 100.0. Prior to selecting oFF or regenerant volume, verify the correct valve body, main piston, regenerant piston, and stack are being used, and that the injector or injector plug(s) are in the correct locations. See Compliance Table in Service Instructions under Injector Cap, Screen, Injector Plug and Injector section and Figure 6. Press NEXT to go to step 4F. Press REGEN to return to previous step.

STEP 4F – Backwash: Select “NORMAL” for one “NORMAL” backwash, “NORMAL 2” for two “NORMAL” backwashes, “LONGER” for one “LONGER” backwash or “LONGER 2” for two “LONGER” backwashes. Selection effects the length of all backwashes. The actual duration of one NORMAL backwash is 14 minutes, one LONGER backwash is 16 minutes, NORMAL 2 backwashes are 8 minutes each, and LONGER 2 backwashes are 12 minutes each (see Tables 7 and 8 for additional details). Press NEXT to go to step 5F. Press REGEN to return to previous step.

STEP 5F – Gallons Capacity: If value is set to:

- “oFF” regeneration will be based solely on the day override set (see Installer Display Settings step 3I); or
- as a number (allowable range 20 to 50,100) regeneration initiation will be based off the value specified.

Increment increase is 20 for the range of 20 to 1000; 50 for the range of 1000 to 10,000 and 100 for the range of 10,000 to 50,100. Hardness display will not be allowed to be set in the Installer Display Settings. See Table 13 for more detail. Press NEXT to go to step 6F. Press REGEN to return to previous step.

STEP 6F – Refill: Select “PoST” to refill the brine tank after the final rinse or select “PrE” to refill the brine tank two hours before the regeneration time set. If “oFF” is selected in Step 3F the display can be left on “PoST” or “PrE” because no refill occurs. Press NEXT to go to step 7F. Press REGEN to return to previous step.

STEP 7F – Regeneration Time Option: Three choices for settings are available “NORMAL”, “on 0” and “NORMAL + on 0”. See Table 13 for more detail. Press NEXT to exit OEM Filter System Setup. Press REGEN to return to previous step.

Installer Display Settings



STEP 1I - Press NEXT and ▲ simultaneously for 3 seconds.

STEP 2I – Hardness: Set the amount of hardness in grains of hardness as calcium carbonate per gallon using the ▼ or ▲ buttons. The default is 20 with value ranges from 1 to 150 in 1 grain increments. Note: The grains per gallon can be increased if soluble iron needs to be reduced. This display will show “-nA-” if “FILTER” is selected in Step 2F or if ‘AUTO’ is not selected in Step 6S. Press NEXT to go to step 3I. Press REGEN to exit Installer Display Settings.

STEP 3I – Day Override: When gallon capacity is set to off, Day Override sets the number of days between regenerations. When gallon capacity is set to AUTO or to a number, Day Override sets the maximum number of days between regenerations. If value set to “oFF” regeneration initiation is based solely on gallons used. If value is set as a number (allowable range from 1 to 28) a regeneration initiation will be called for on that day even if sufficient number of gallons were not used to call for a regeneration. Set Day Override using ▼ or ▲ buttons:

- number of days between regeneration (1 to 28); or
- “oFF”.

See Table 12 for more detail on softener setup and Table 13 for more detail on filter setup. Press NEXT to go to step 4I. Press REGEN to return to previous step.

STEP 4I – Next Regeneration Time (hour): Set the hour of day for regeneration using ▼ or ▲ buttons. AM/PM toggles after 12. The default time is 2:00 a.m. This display will show “REGEN on 0 GAL” if “on 0” is selected in Step 9S or Step 7F. Press NEXT to go to step 5I. Press REGEN to return to previous step.

STEP 5I – Next Regeneration Time (minutes): Set the minutes of day for regeneration using ▼ or ▲ buttons. This display will not be shown if “on 0” is selected in Step 9S or Step 7F. Press NEXT to exit Installer Display Settings. Press REGEN to return to previous step.

To initiate a manual regeneration immediately, press and hold the “REGEN” button for three seconds. The system will begin to regenerate immediately. The control valve may be stepped through the various regeneration cycles by pressing the “REGEN” button.

User Display Settings

General Operation

When the system is operating one of two displays will be shown. Pressing NEXT will alternate between the displays. One of the displays is always the current time of day. The second display is one of the following: days remaining or gallons remaining. Days remaining is the number of days left before the system goes through a regeneration cycle. Capacity remaining is the number of gallons that will be treated before the system goes through a regeneration cycle. The user can scroll between the displays as desired.

If the system has called for a regeneration that will occur at the preset time of regeneration, the words REGEN TODAY will appear on the display.

When water is being treated (i.e. water is flowing through the system) the word “Softening” or “Filtering” flashes on the display if a water meter is installed.

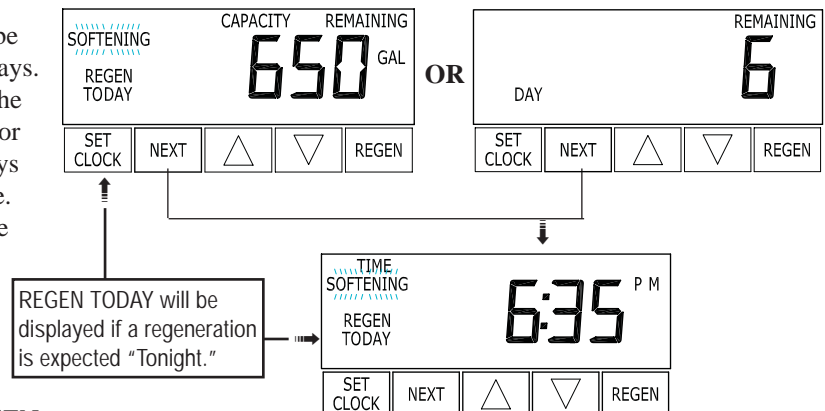

Regeneration Mode

Typically a system is set to regenerate at a time of low water usage. An example of a time with low water usage is when a household is asleep. If there is a demand for water when the system is regenerating, untreated water will be used.

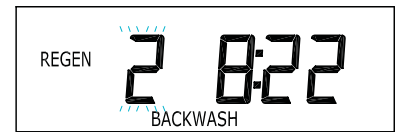

When the system begins to regenerate, the display will change to include information about the step of the regeneration process and the time remaining for that step to be completed. The system runs through the steps automatically and will reset itself to provide treated water when the regeneration has been completed.

Manual Regeneration

Sometimes there is a need to regenerate the system sooner than when the system calls for it, usually referred to as manual regeneration. There may be a period of heavy water usage because of guests or a heavy laundry day.

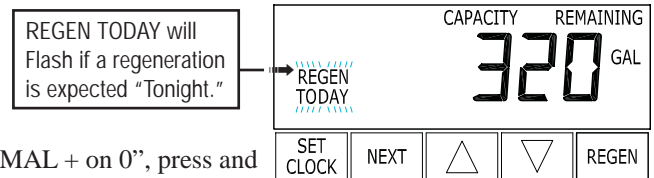

To initiate a manual regeneration at the preset delayed regeneration time, when the regeneration time option is set to "NORMAL" or "NORMAL + on 0", press and release "REGEN". The words "REGEN TODAY" will flash on the display to indicate that the system will regenerate at the preset delayed regeneration time. If you pressed the "REGEN" button in error, pressing the button again will cancel the request. Note: If the regeneration time option is set to "on 0" there is no set delayed regeneration time so "REGEN TODAY" will not activate if "REGEN" button is pressed.

To initiate a manual regeneration immediately, press and hold the "REGEN" button for three seconds. The system will begin to regenerate immediately. The request cannot be cancelled.

Note: For softeners, if brine tank does not contain salt, fill with salt and wait at least two hours before regenerating.

Set Time of Day

The user can also set the time of day. Time of day should only need to be set after power outages lasting more than 8 hours, if the battery has been depleted and a power outage occurs, or when daylight saving time begins or ends. If a power outage lasting more than 8 hours occurs, the time of day will flash on and off which indicates the time of day should be reset. If a power outage lasts less than 8 hours and the time of day flashes on and off, the time of day should be reset and the battery replaced.

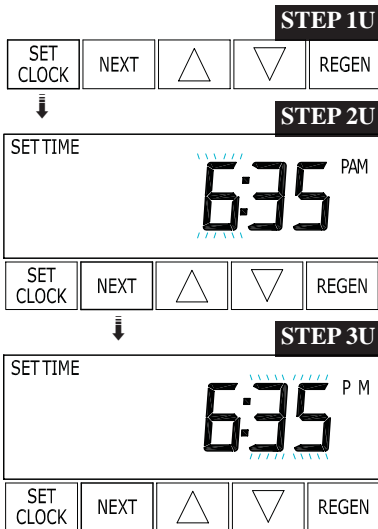

STEP 1U – Press SET CLOCK.

STEP 2U - Current Time (hour): Set the hour of the day using ▼ or ▲ buttons. AM/PM toggles after 12. Press NEXT to go to step 3U.

Power Loss

If the power goes out, the system will keep time for up to 8 hours or until the battery is depleted. If a power outage of more than 8 hours occurs, the time of day will flash on and off which indicates the time of day should be reset. The system will remember the rest. If a power outage lasts less than 8 hours and the time of day flashes on and off, the non rechargeable battery should be replaced.

Error Message

If the word "ERROR" and a number are alternately flashing on the display contact the OEM for help. This indicates that the valve was not able to function properly.

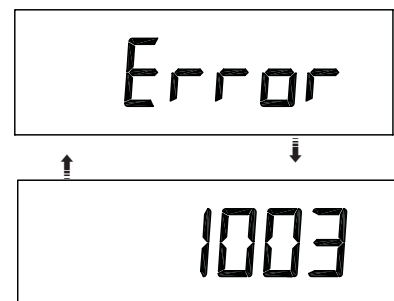

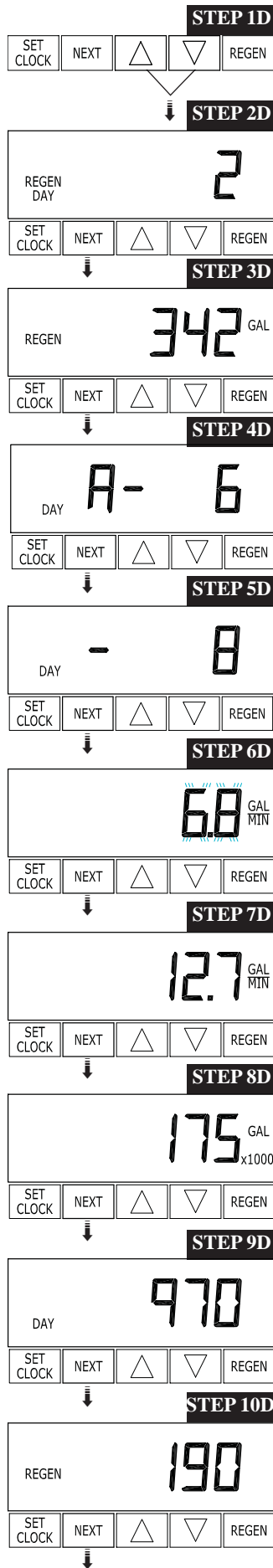

Diagnostics

STEP 1D – Press ▼ or ▲ simultaneously for three seconds. If screen in step 2D does not appear in 5 seconds the lock on the valve is activated. To unlock press ▼, NEXT, ▲, and SET CLOCK in sequence, then press NEXT and ▼ simultaneously for 3 seconds.

STEP 2D¹⁵ – Days, since last regeneration: This display shows the days since the last regeneration occurred. Press the NEXT button to go to Step 3D. Press REGEN to exit Diagnostics.

STEP 3D – Gallons, since last regeneration: This display shows the number of gallons that have been treated since the last regeneration. This display will equal zero if a water meter is not installed. Press the NEXT button to go to Step 4D. Press REGEN to return to previous step.

STEP 4D – Gallons, reserve capacity used for last 7 days: If the valve is set up as a softener, a meter is installed and Set Gallons Capacity is set to “Auto,” this display shows 0 day (for today) and flashes the reserve capacity. Pressing the ▲ button will show day 1 (which would be yesterday) and flashes the reserve capacity used. Pressing the ▲ button again will show day 2 (the day before yesterday) and the reserve capacity. Keep pressing the ▲ button to show the gallons for days 3, 4, 5 and 6. The ▼ button can be pressed to move backwards in the day series. Press the NEXT button at any time to go to Step 5D. Press REGEN to return to previous step.

STEP 5D - Gallons, 63 day usage history: This display shows day 1 (for yesterday) and flashes the number of gallons treated yesterday. Pressing the ▲ button will show day 2 (which would be the day before yesterday) and flashes the number of gallons treated on that day. Continue to press the ▲ button to show the maximum number of gallons treated for the last 63 days. This display will show dashes if a water meter is not installed. Press the NEXT button at any time to go to Step 6D. Press REGEN to return to previous step.

STEP 6D – Flow rate, current: Turn the water on at one or more taps in the building. The flow rate in gallons per minute will be displayed. If flow stops the value will fall to zero in a few seconds. This display will equal zero if a water meter is not installed. Press the NEXT button to go to Step 7D. Press REGEN to return to previous step.

STEP 7D – Flow rate, maximum last seven days: The maximum flow rate in gallons per minute that occurred in the last seven days will be displayed. This display will equal zero if a water meter is not installed. Press the NEXT button to go to Step 8D. Press REGEN to return to previous step.

STEP 8D – Gallons, total used since last reset: The total number of gallons used since last reset will be displayed. This display will equal zero if a water meter is not installed. Press the NEXT button to go to Step 9D. Press REGEN to return to previous step.

STEP 9D – Days, total number since last reset: The total number of days the control valve has been in service since last reset will be displayed. Press the NEXT button to go to Step 10D. Press REGEN to return to previous step.

STEP 10D – Regenerations, total number since last reset: The total number of regenerations that have occurred since last reset will be displayed. Press the NEXT button to exit Diagnostics. Press REGEN to return to previous step.

¹⁵ The values in steps 2D through 5D and 7D through 10D can be reset to zero. See Table 14, Reset Diagnostic Settings for procedure. Resetting one value resets them all.

RETURN TO
NORMAL MODE

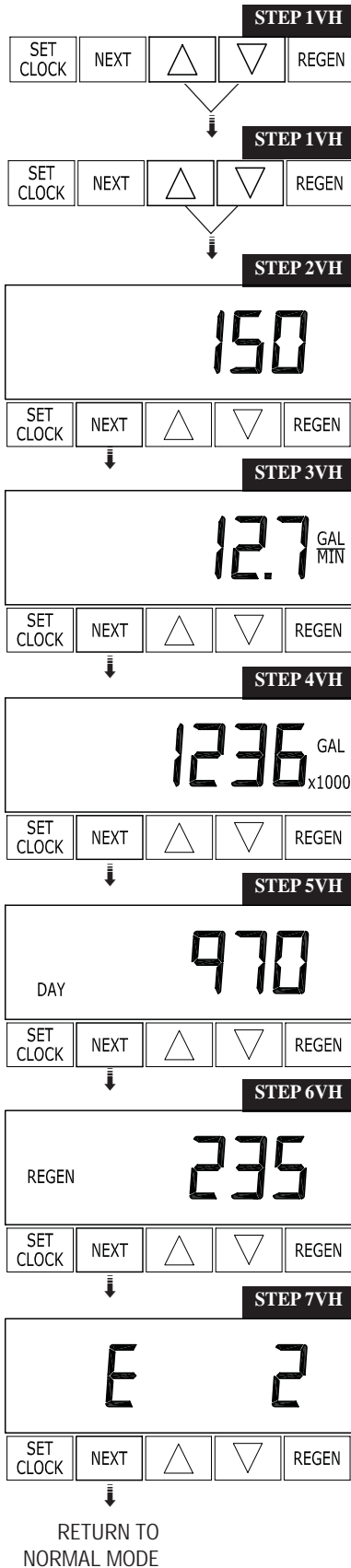

Valve History

STEP 1VH – Press ▲ and ▼ simultaneously for three seconds and release. Then press ▲ and ▼ simultaneously and release. If screen in step 2VH does not appear in 5 seconds the lock on the valve is activated. To unlock press ▼, NEXT, ▲, and SET CLOCK in sequence, then press ▲ and ▼ simultaneously for 3 seconds and release. Then press ▲ and ▼ simultaneously and release.

STEP 2VH – Software Version: This display shows the software version of the valve. Press the NEXT button to go to Step 3VH. Press REGEN to exit Valve History.

STEP 3VH¹⁶ – Flow rate, maximum since startup: This display shows the maximum flow rate in gallons per minute that has occurred since startup. This display will equal zero if a water meter is not installed. Press the NEXT button to go to Step 4VH. Press REGEN to return to previous step.

STEP 4VH – Gallons, total used since start-up: This display shows the total gallons treated since startup. This display will equal zero if a water meter is not installed. Press the NEXT button to go to Step 5VH. Press REGEN to return to previous step.

STEP 5VH – Days, total since start-up: This display shows the total days since startup. Press the NEXT button to go to Step 6VH. Press REGEN to return to previous step.

STEP 6VH – Regenerations, total number since start-up: This display shows the total number of regenerations that have occurred since startup. Press the NEXT button to go to Step 7VH. Press REGEN to return to previous step.

STEP 7VH – Error, number of occurrences since start-up: This display shows E and the total number of errors that have occurred since startup. Press the NEXT button to exit Valve History. Press REGEN to return to previous step.

¹⁶ Values in steps 3VH through 7VH cannot be reset.